

PRESSURE REDUCING VALVE DMV 755

Nominal size DN 10–50

Nominal size 3/8"–2"

Nominal pressure PN 10 bar



Features

- pressure setting range 1 to 9 bar
- control valve for reliable reduction of system pressures to constant operating pressures
- constant, low vibration control behavior
- high reproducibility of the set pressure
- pressure setting possible at any time, also during operation

Additional options on request

- silicone free
- pressure presetting
- pressure gauge hole
- sealed
- NSF certification

www.asv-stuebbe.com/produkte/mess-und-regeltechnik



Pictogram Pressure Reducing Valve DMV 755

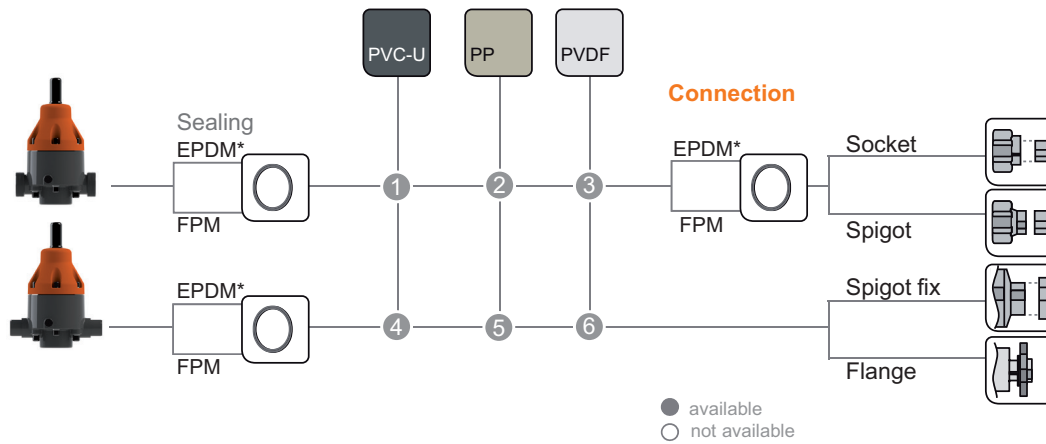

Diaphragm PTFE (EPDM)

Pressure Gauge Installation

Valves with 2 Threaded Holes G 1/4" incl. Plug



Pressure setting range 1.0–9.0 bar
Pressure settings in 0.5 bar steps

On Demand

- » Sealing
- » Cleaning (Free of Surface Disturbing Substances)

* EPDM-Seal in Combination with PVC-U resp. PP-Valve.

Basic Nominal Sizes:

DN 8	DN 10	DN 15	DN 20	DN 25	DN 32	DN 40	DN 50	DN 65	DN 80	DN 100	DN 125	DN 150	DN 200	DN 250	DN 300	DN 350	DN 400
------	-------	-------	-------	-------	-------	-------	-------	-------	-------	--------	--------	--------	--------	--------	--------	--------	--------

Connection Material (process connection)

<p>1 PVC-U socket DIN, ANSI, BS, JIS female thread Rp 1.4571 female thread Rp male thread R PE100 spigot DIN (95 mm)</p> <p>2 PP socket DIN female thread Rp PP spigot (IR)</p> <p>3 PVDF socket DIN PVDF spigot (IR)</p>	<p>4 PVC-U spigot fix PP/St. flange DIN, ANSI GFK flange DIN</p> <p>5 PP spigot fix* PP/St. flange DIN, ANSI GFK flange DIN</p> <p>6 PVDF spigot fix* PP/St. flange DIN, ANSI</p> <p>* only for socket welding.</p>
---	--

Pressure Reducing Valve DMV 755

Use

- chemical plant engineering
- industrial plant engineering
- water treatment

Application

- The pressure reducing valve which is directly controlled by the medium, is used in technical processing plants for reducing primary pressures to system dependent working pressures and for controlled maintenance of working pressures. Not suitable as equipment with safety function according to the pressure vessel directive.

Valve function

- The opened valve is in equilibrium between the inlet pressure (primary side) and the lower working pressure (secondary side). If the working pressure goes above or below the desired value, the large area membrane is lifted against the spring force or pressed down by the spring force. The valve starts closing or opening until the equilibrium condition is reached again, i.e. the working pressure remains constant independent of an increasing or decreasing inlet pressure (as long as the inlet pressure > working pressure).

Valve setting

- Set or adjust the desired or permissible working pressure at the adjustment screw with the aid of pressure gauges (ASV diaphragm pressure gauge guard, type MDM 902) in the pipe system after removing the protection cap.
The adjustment screw is secured by a counter nut and can be sealed against unauthorized adjustment, if necessary.
- There is a differentiation between:
secondary pressure - system closed or
secondary pressure - system dynamically flowing

Flow medium

- Technically pure, neutral and aggressive fluids, provided that the selected valve materials coming into contact with the media are resistant at the operating temperature according to the ASV resistance guide.

Flow direction

- always in the direction of the arrow, see the „sectional drawing“ graphic

ASV resistance guide

www.asv-stuebbe.de/pdf_resistance/300051.pdf

Process temperature

- See the „pressure/temperature diagram“ graphic

Process pressure

- See the „pressure/temperature diagram“ graphic

Nominal pressure (H₂O, 20 °C)

- PN 10 bar

Size

- DN 10–50

Pressure setting range

- 1–9 bar

Working pressure

- set pressure minus flow dependent pressure reduction (see characteristic curves):
secondary pressure 1–9 bar

Constant working pressure

- Difference between the maximum and minimum secondary pressure, caused by primary pressure fluctuations: approx. ± 0.2 bar

Hysteresis

- Difference between opening and closing pressure approx. 0.1–0.4 bar

Actuation

- medium controlled

Device connection

- see graphics
„Pictograph, pressure reduction valve DMV 755“

Material with medium contact

Housing:

- PVC-U, PP, PVDF

bonnet:

- PP, glass fiber reinforced

Diaphragm:

- PTFE

(EPDM diaphragm, PTFE-coated on the medium side)

Sealing:

- FPM, EPDM

Material without medium contact

Screws:

- stainless steel (1.4301)

Mounting position

- as required

Fastening

- via threaded inserts (metal inserts) in the valve body

Color

- bonnet: orange, RAL 2004
- bottom section: PVC-U, gray, RAL 7011
- bottom section: PP, gray, RAL 7032
- bottom section: PVDF, opaque, yellowish-white

Pressure gauge connection

- The pressure reducing valves can be factory fitted with a pressure gauge for neutral media. The resistance of the pressure gauge material has to be taken into consideration for other medium types.

Pressure gauge preparation

- Housing holes on both ends G 1/4" incl. plug

Pressure gauge

- Chemical version, damped
- Chemical version, not damped
- Contact pressure gauge

Pressure/temperature diagram

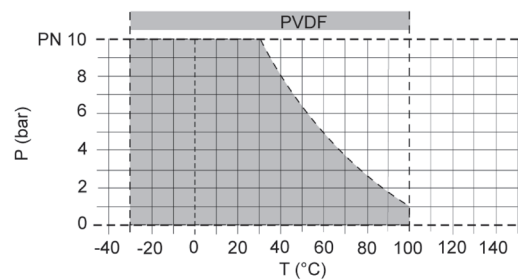
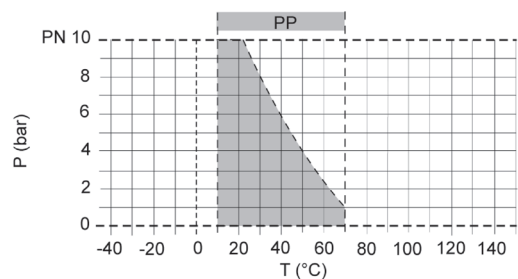
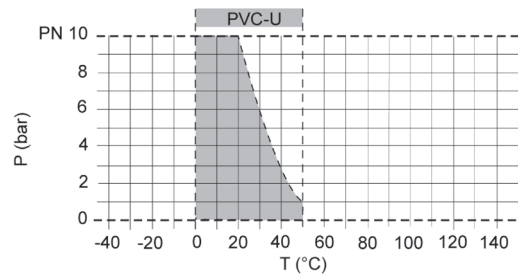

Description	
P	Operating pressure
T	Temperature

The pressure/temperature limits of the materials are valid for the stated nominal pressures and a service life of 25 years. These values are guide values for flow medium types which do not negatively impact the physical and chemical characteristics of the valve material. It may be necessary to take diminution factors into consideration. The durability of wear parts depends on the operating conditions of the application.

Pressure Reducing Valve DMV 755

Operating behavior

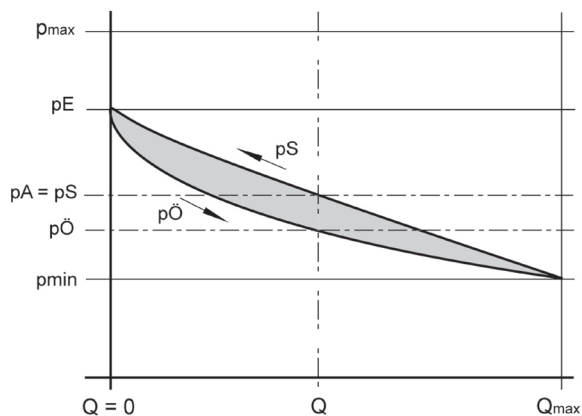

	Description
pE	set pressure
pA	Working pressure
p _{max}	maximum pressure
p _{min}	minimum pressure
pO	opening pressure
pS	closing pressure
pO-pS	hysteresis
pA-pE	flow dependent pressure reduction
Q	Flow

Characteristic curve, design example

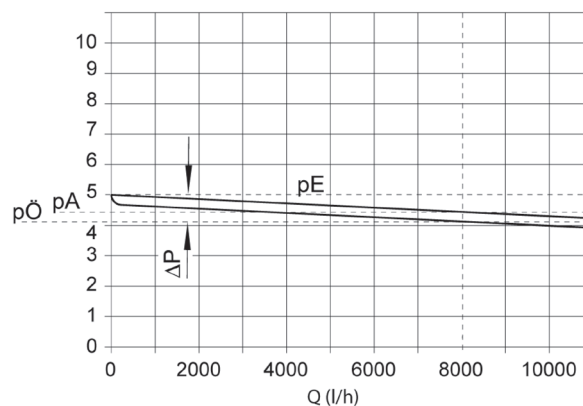

The valve is set tight at 5 bar.
 Desired flow rate 8000 l/h, medium H₂O.
 According to the curve, this results in the following values:
 Set pressure pE: 5 bar
 pressure reduction: 0.8 bar
 working pressure pA: 4.4 bar

	Description
pA	Working pressure
pE	set pressure
pO	opening pressure
Δp	Pressure loss
Q	Flow

Characteristic curve, set range

DN 10

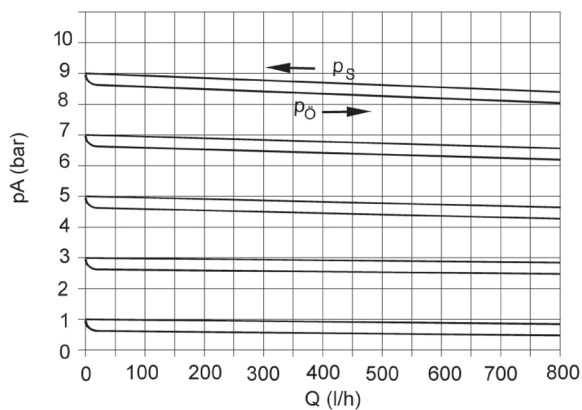

Pressure Reducing Valve DMV 755

DN 15

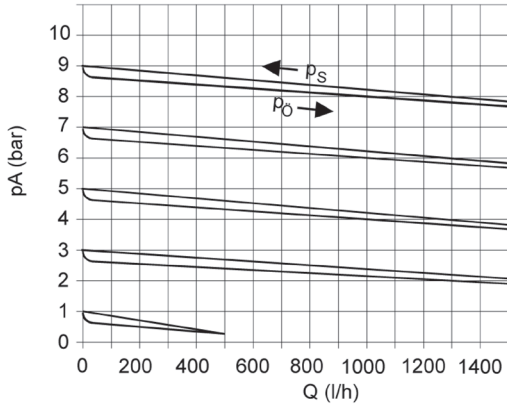

DN 32

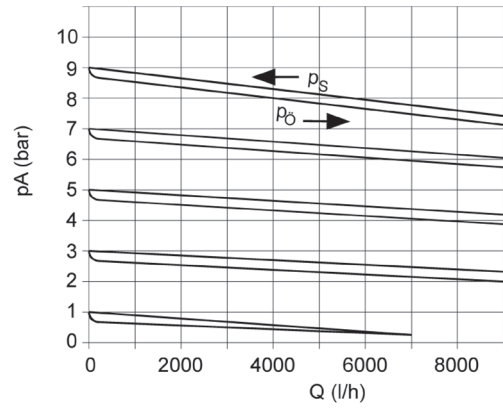

DN 20

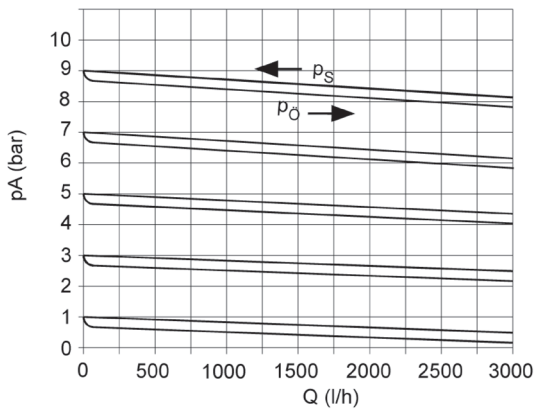

DN 40

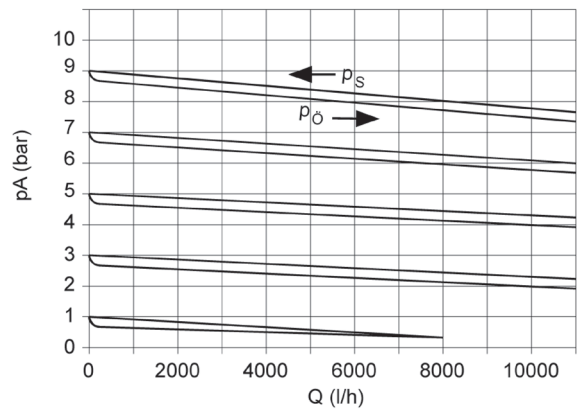

DN 25

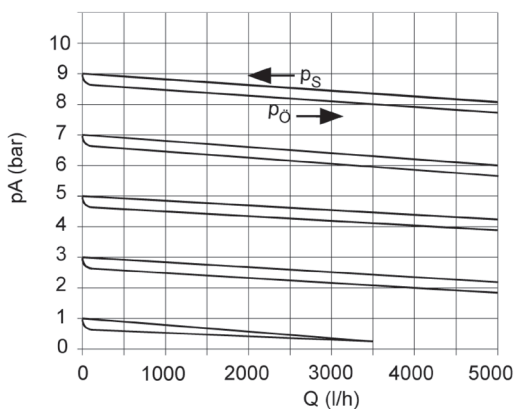

DN 50

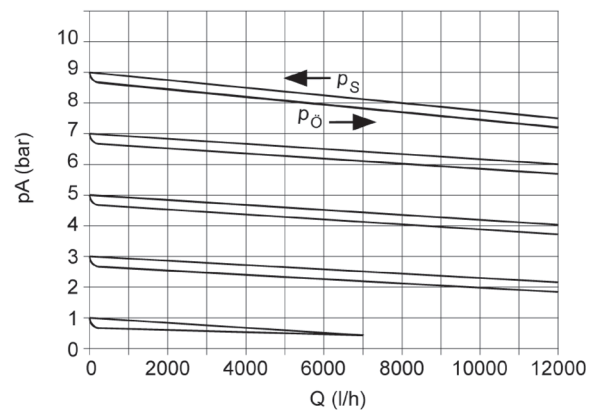

Description	
pA	Working pressure
pS	closing pressure
pÖ	opening pressure
Q	Flow

Pressure Reducing Valve DMV 755

Applications for pressure reduction valves

Example 1: secondary pressure - system dynamically flowing

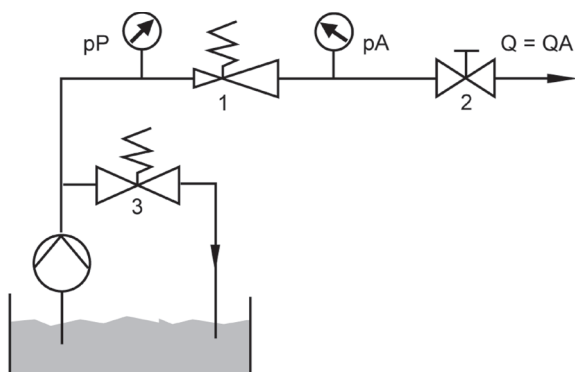

If the stop valve is closed, the working pressure p_A rises by the amount of the closing pressure p_S .

Example 2: secondary pressure - system closed

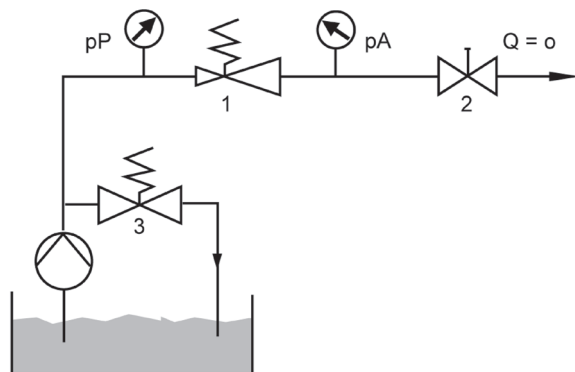

If the stop valve is opened, the working pressure p_A drops by the amount of the opening pressure $p_{\ddot{O}}$.

	Description
p_A	Working pressure
p_P	Pump pressure
Q	Flow
Q_A	Flow in the working point
1	Pressure reducing valve
2	Stop valve
3	Pressure relief valve

Pressure Reducing Valve DMV 755

Connection socket

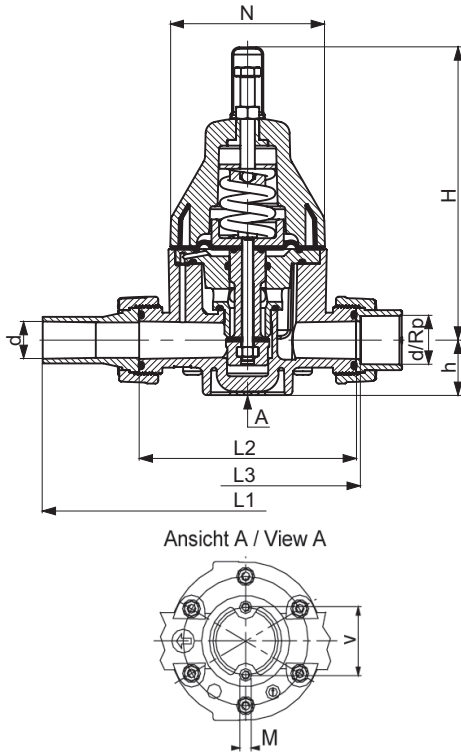

Connection spigot

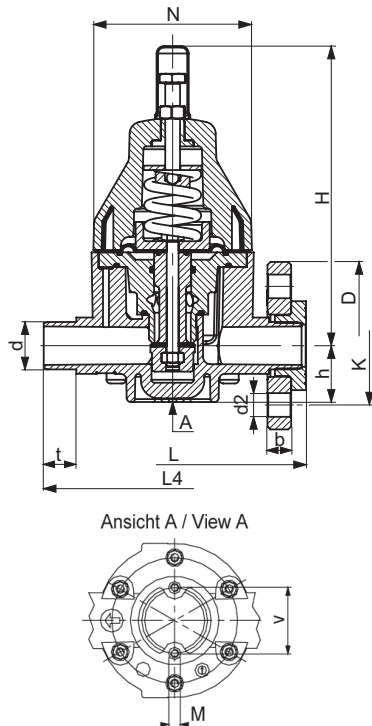

d (mm)		16	20	25	32	40	50	63	
DN (mm)		10	15	20	25	32	40	50	
DN (inch)		3/8	1/2	3/4	1	1 1/4	1 1/2	2	
valve body	Insert/flange								
b	GFR flange DIN	-	12.2	14	15	17	17	18	
	PP/st. flange DIN	-	13	14.5	15.5	17.5	17.5	19	
	PP/st. flange ANSI	-	12	12	16	16	18	18	
d2	GFR flange DIN	-	14	14	14	18	18	18	
	PP/st. flange DIN	-	14	14	14	18	18	18	
	PP/st. flange ANSI	-	16	16	16	16	16	20	
D	GFR flange DIN	-	96.5	106	115	142	152	168	
	PP/st. flange DIN	-	96	106	116	141	151	166	
	PP/st. flange ANSI	-	95	105	113	130	133	160	
G*		3/4	1	1 1/4	1 1/2	2	2 1/4	2 3/4	
h	PVC-U, PP, PVDF	25	25	38	38	56	56	56	
H	PVC-U, PP, PVDF	174	174	202	202	262	262	262	
K	GFR flange DIN	-	65	75	85	100	110	125	
	PP/st. flange DIN	-	60	70	80	89	98	121	
	PP/st. flange ANSI	-	65	75	85	100	110	125	
L		-	150	180	180	230	230	250	
L1	PVC-U	PE100 Spigot DIN	-	310	340	340	405	433	453
	PP	PP spigot	-	228	264	270	331	338	343
	PVDF	PVDF spigot	-	225	262	268	324	331	336
L2	PVDF		120	120	150	150	200	201	200
	PP, PVC-U		120	120	150	150	205	205	205
L3	PVC-U	Socket PVC-U DIN, PVC-U ANSI, BS	126	126	156	156	211	211	211
		Socket PVC-U JIS	132	128	160	159	211	211	213
		PVC-U female thread Rp	126	127.6	158	162.6	221	231	235.6
		Female thread 1.4571	130	130	161	164	221	223	223
	PP	PP socket DIN	128	126	156	156	211	211	211
		PP female thread Rp	-	126	156	156	211	213	215
PVDF	PVDF socket DIN	127	125	156	156	206	207	206	
L4		144	144	174	174	224	224	244	
M		6	6	6	6	8	8	8	
N		81	81	107	107	147	147	147	
Rp*		3/8	1/2	3/4	1	1 1/4	1 1/2	2	
t		14	16	19	22	26	31	38	
V	PP, PVC-U, PVDF	40	40	46	46	65	65	65	

all dimensions in mm / * dimensions in inch

Pressure Reducing Valve DMV 755

Sectional drawing

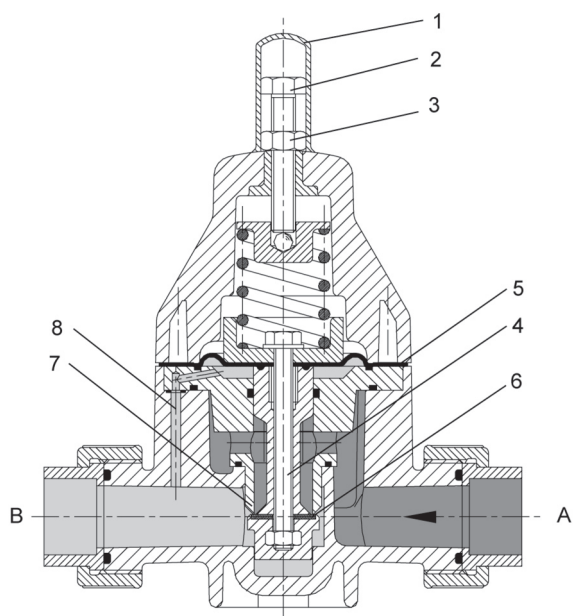

	Description
A	primary side
B	secondary side
1	Protection cap
2	adjustment screw
3	counter nut
4	piston
5	diaphragm
6	flat sealing ring
7	valve seat
8	control bore hole

Pressure Reducing Valve DMV 755

Components

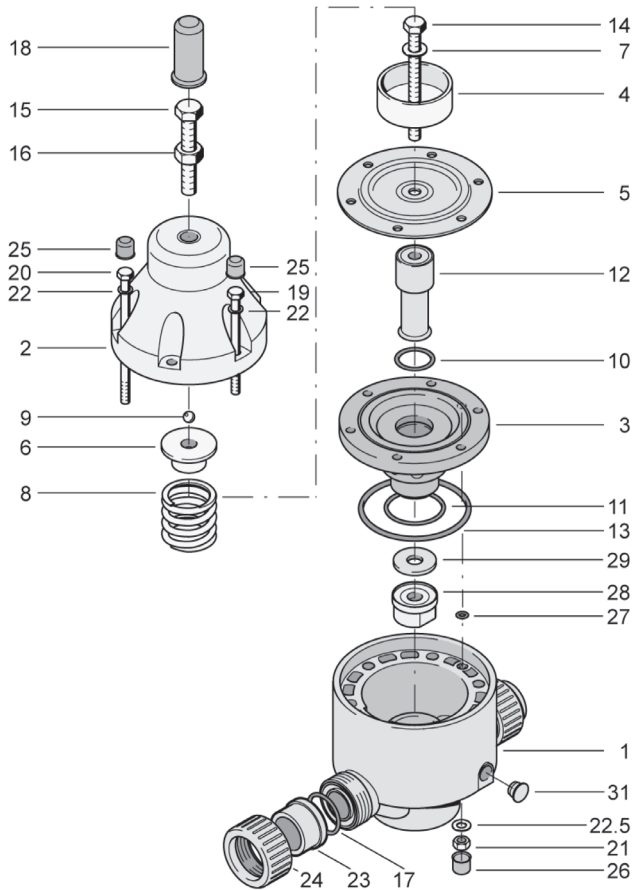

	Quantity DN 10-15	Quantity DN 20-50	Description
1	1	1	housing, complete
2	1	1	bonnet
3	1	1	separating disc
4	1	1	spring plate
5	1	1	diaphragm
6	1	1	pressure plate
7	1	1	Washer
8	1	1	pressure spring
9	1	1	steel ball
10	1	1	O-ring
11	1	1	O-ring
12	1	1	piston
13	1	1	O-ring
14	1	1	hexagon screw
15	1	1	hexagon screw
16	1	1	hexagon nut
17	2	1	O-ring
18	1	1	Protection cap
19	4	2	hexagon screw
20	-	4	hexagon screw
21	4	6	hexagon nut
22	4	6	Washer
22.5	4	6	Washer
23	2	2	Union end
24	2	2	Union nut
25	4	6	Protection cap
26	4	6	Protection cap
27	1	1	O-ring
28	1	1	piston guidance
29	1	1	flat sealing ring
31	2	2	plug