

TORQUE

| SIZE | Kg.m | N.m |
|-----------|------|------|
| 1/2"-3/4" | 80 | 7.85 |
| 1" | 80 | 7.85 |
| 1-1/2" | 100 | 9.81 |
| 2" | 100 | 9.81 |

1Kg m=0.0981N.m

CV

| CV [GMP/(1bf/in ²) ^{1/2}] | |
|---|-------|
| OPENING: 100% | |
| Dia | CV |
| 1/2" | 3.27 |
| 3/4" | 5.29 |
| 1" | 8.87 |
| 1-1/2" | 31.09 |
| 2" | 43.15 |

1/2" a 2"

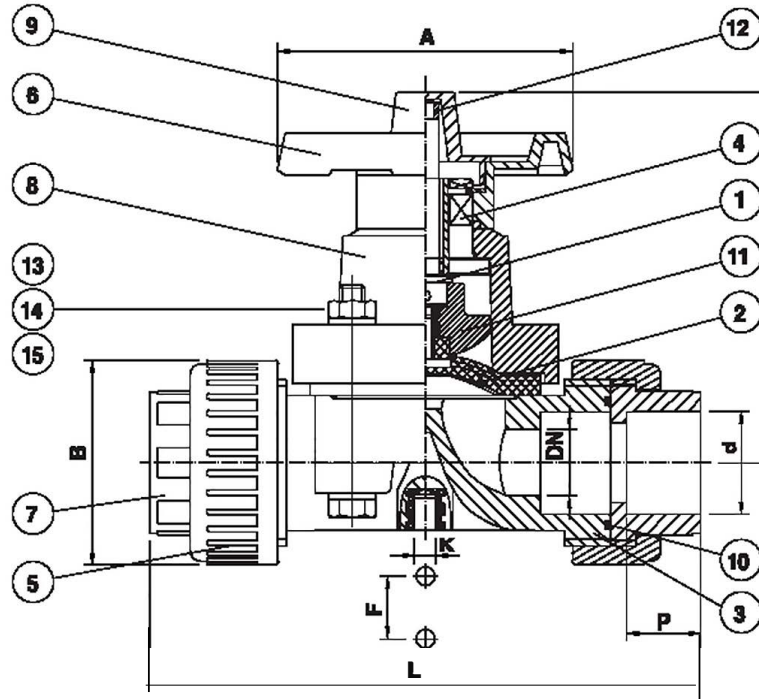

| Standards | JIS | | | | | | | | | | ANSI | | | | | | | | | | DIN | | | | | | | | | | | | |
|-----------|----------|---------|------|-----|-----|-----|-----|----|----------------------------------|-----------------------|------------|------|----------|-------|-------|-------|-------|-------|----------------------------------|-----------------------|----------|-----|----|--------|------|-----|-----|-----|----------------------------------|-----------------------|-------|---|----|
| | Unit: mm | | | | | | | | | | Unit: Inch | | | | | | | | | | Unit: mm | | | | | | | | | | | | |
| | d | P | B | L | H | A | F | K | Test Pres. (kg/cm ²) | File Rubber dia. Dia. | d | P | B | L | H | A | F | K | Test Pres. (lb/in ²) | File Rubber dia. Dia. | d | P | B | L | H | A | F | K | Test Pres. (kg/cm ²) | File Rubber dia. Dia. | | | |
| 15-1/2" | 22 | PT1/2 | 22.2 | 54 | 166 | 104 | 81 | 25 | 5/16" | 7 | 10 | 0.84 | NPT1/2 | 0.875 | 2.126 | 6.53 | 4.094 | 3.189 | 0.984 | 5/16" | 104 | 148 | 20 | R1/2 | 16.0 | 54 | 166 | 104 | 81 | 25 | 5/16" | 7 | 10 |
| 20-3/4" | 26 | PT3/4 | 25.4 | 54 | 168 | 104 | 81 | 25 | 5/16" | 7 | 10 | 1.05 | NPT3/4 | 1.000 | 2.126 | 6.53 | 4.094 | 3.189 | 0.984 | 5/16" | 104 | 148 | 25 | R1/4 | 18.5 | 54 | 168 | 104 | 81 | 25 | 5/16" | 7 | 10 |
| 25-1" | 32 | PT1 | 28.6 | 63 | 183 | 116 | 91 | 25 | 5/16" | 7 | 10 | 1.32 | NPT1 | 1.125 | 2.480 | 7.2 | 4.567 | 3.583 | 0.984 | 5/16" | 104 | 148 | 32 | R1 | 22.0 | 63 | 183 | 116 | 91 | 25 | 5/16" | 7 | 10 |
| 32-1 1/4" | 38 | PT1 1/4 | 31.8 | 89 | 238 | 142 | 117 | 45 | 5/16" | 7 | 10 | 1.68 | NPT1-1/4 | 1.250 | 3.5 | 8.97 | 5.591 | 4.606 | 1.772 | 5/16" | 104 | 148 | 40 | R1-1/4 | 28.0 | 88 | 238 | 142 | 117 | 45 | 5/16" | 7 | 10 |
| 40-1 1/2" | 48 | PT1 1/2 | 34.9 | 89 | 238 | 142 | 117 | 45 | 5/16" | 7 | 10 | 1.90 | NPT1-1/2 | 1.375 | 3.5 | 8.97 | 5.591 | 4.606 | 1.772 | 5/16" | 104 | 148 | 50 | R1-1/2 | 31.0 | 88 | 238 | 142 | 117 | 45 | 5/16" | 7 | 10 |
| 50-2" | 60 | PT2 | 38.1 | 101 | 273 | 176 | 150 | 45 | 5/16" | 7 | 10 | 2.38 | NPT2 | 1.500 | 3.87 | 10.74 | 6.828 | 5.906 | 1.772 | 5/16" | 104 | 148 | 63 | R2 | 37.5 | 101 | 273 | 176 | 150 | 45 | 5/16" | 7 | 10 |

| Item | Parte | Pcs | Materials | Item | Parte | Pcs | Materials |
|------|---------------|-----|----------------------|------|-------------|-----|-----------------------------|
| 1 | Shaft | 1 | BRASS | 9 | Gauge Cover | 1 | PC |
| 2 | Diaphragm | 1 | EPDM, TEFLON | 10 | O'ring | 2 | EPDM, VITON |
| 3 | Body | 1 | UPVC, PP, CPVC, PVDF | 11 | Compressor | 1 | 15A-25A PVDF 32A-50A PPG |
| 4 | Sleeve | 1 | BRASS | 12 | Indicator | 1 | PE |
| 5 | Union Nut | 2 | UPVC, PP, CPVC, PVDF | 13 | Boit | 4 | SUS304 |
| | Handle | 1 | ABS | 14 | Nut | 4 | SUS304 |
| | End Connector | 2 | UPVC, PP, CPVC, PVDF | 15 | | 8 | SUS304 |
| 6 | Bonnet | 1 | UPVC, PP, CPVC, PVDF | | | | |